

**2025 Assessment Year** **Town of Sheboygan, Sheboygan County (2025 Assessment Year)** **Property Records**



Current Owner
KRISTINE A OLSON

Districts	
Sheboygan County	Sheboygan County
Sheboygan	Town of Sheboygan
Sanitary	Sanitary District #2 (Sewer)
School	Sch D of Sheboygan (5271)
Voc/Tech College	Vtech School 1100
Water Drainage	Sanitary District #3 (Water)

General Information			
Parcel Number:	365630		
Alternate ID:	59024365630		
Neighborhood:	126 - Mueller Field		
Neighborhood Group:	Residential		
Sanitary	Sewer		
Traffic	Light		
Water	Municipal water		

Total Acreage:	0.42
Total Sq. Ft:	18,295
Actual Frontage:	
Effective Frontage:	117
Effective Depth:	158
Water Influence:	None
Water Desirability:	None

*Legal Description
MUELLER FIELD SUBDIVISION - LOT 17
*This legal description may be abbreviated and is for assessment purposes only.
Section: 08      Township: 15      Range: 23E
Subdivision:      Block:      Lot / Unit:

Inspection Data		
Date	User	Type

Property Sales / Ownership History						
Sale Date	Sale Price	Sale Typ	Validity	Document #	Deed Type	Grantor
4/2/2022	\$599,900	IMPROVED	2 - Valid improved sale	2134931	1 - Warranty	Patel Living Trust of 2016, Dated August 10, 2016
11/10/2016	\$330,500		5 - Not a market sale	2034111	3 - Quit claim	Patel Devraj
11/10/2016	\$330,500		5 - Not a market sale	2033538	3 - Quit claim	Patel Living Trust of 2016
8/8/2016	\$330,500		5 - Not a market sale	2025389	1 - Warranty	Patel Devraj

Summary of 2025 Assessment Year Values					
Tax Classification	Code	Acres	Land	Improvement	Total
Residential	1	0.420	\$42,000	\$608,700	\$650,700
<b>Total Real Estate - All Columns:</b>		<b>0.420</b>	<b>\$42,000</b>	<b>\$608,700</b>	<b>\$650,700</b>

Assessment Value History					
Year	Code	Acres	Land	Improvement	Total
2025	1	0.420	\$42,000	\$608,700	\$650,700
	<b>Totals</b>	<b>0.420</b>	<b>\$42,000</b>	<b>\$608,700</b>	<b>\$650,700</b>
2024	1	0.420	\$42,000	\$608,700	\$650,700
	<b>Totals</b>	<b>0.420</b>	<b>\$42,000</b>	<b>\$608,700</b>	<b>\$650,700</b>
2023	1	0.420	\$35,000	\$303,000	\$338,000
	<b>Totals</b>	<b>0.420</b>	<b>\$35,000</b>	<b>\$303,000</b>	<b>\$338,000</b>

Special Tax Programs (MFL/PFC) and Exempt					
Tax Classification	Code	Acres	Land	Improvement	Total

Permit Information				
Issued Date	Number	Amount	Status	Purpose/Description
2007-03-18	8-2007	\$ 0	Completed	New house



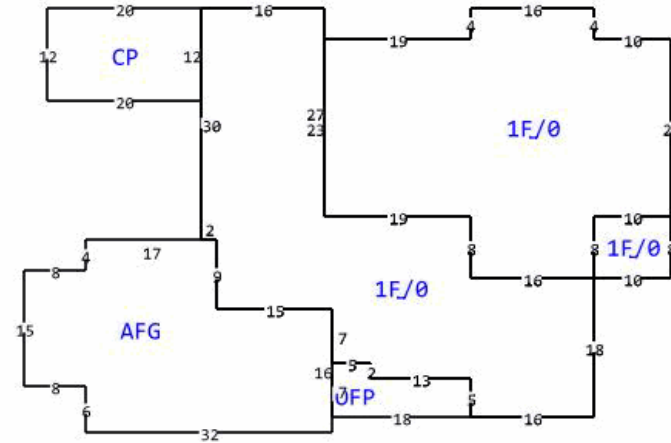

Building Data			
Tax Classification	Residential	Additional Fixtures	NO
Building Number/Section	1 - 1	Hot Tub	NO
Building Style	Ranch (1970+)	Plumbing Rough In	NO
Quality/Grade	B-	Family Rooms	NO
Year Built	2007	Other Rooms	NO
Effective Year Built	2007	Masonry Fireplace Stacks	NO
Class/Const	Frame	Masonry Fireplace Openings	NO
Overall Condition (CDU)	Average	Masonry Additional Stories	NO
Occupancy (Use)	Single Family	Metal Fireplace Stacks	YES
Living/Apartment Units	1	Metal Fireplace Openings	YES
Stories	1 story	Metal Additional Stories	NO
Roof Type	Asphalt shingles	Gas Fireplace Openings	NO
Basement Type	Not Specified	Equipment Rating	Average
Exterior Wall	Cement fiber board	Kitchen Rating	Average
Masonry Adjustment SF	150	Bath Rating	Average
Shed Dormer LF	0	Interior Rating	Average
Gable Dormer LF	6	Exterior Rating	Average
Heating	Gas, forced air	Rec Room Rating	No Code
Air Conditioning	A/C (same ducts)		
Bedrooms	3		
Bath-Full	3		
Bath-Half	1		
Whirlpool	0		

Building Area					
Living Area	Sq. Ft.	Other Area	Sq. Ft.	Attachment Area	Sq. Ft.
First Floor Area	2,581	Unfinished Attic Area	0	Attached garage, frame	785
Second Floor Area	0	Unfinished Area	0	Concrete patio	240
Third Floor Area	0	Basement Area	2,581	Open frame porch, first floor	100
Half Floor Area	0	Crawlspace Area	0		
Finished Attic Area	0	Finished Basement Area (FBLA)	1,227		
		Rec Room Area	0		
<b>Total Above Grade Living Area</b>	<b>2,581</b>	<b>Total Sq. Ft. Living Area (SFLA)</b>	<b>3,808</b>		