

2025 Assessment Year

Town of Sheboygan, Sheboygan County (2025 Assessment Year)

Property Records



Current Owner
JARED P GRUENKE

Districts	
Sheboygan County	Sheboygan County
Sheboygan	Town of Sheboygan
Sanitary	Sanitary District #2 (Sewer)
School	Sch D of Sheboygan (5271)
Voc/Tech College	Vtech School 1100
Water Drainage	Sanitary District #3 (Water)

General Information			
Parcel Number:	358820		
Alternate ID:	59024358820		
Neighborhood:	129 - Pigeon River Heights		
Neighborhood Group:	Residential		
Sanitary	Sewer		
Traffic	Light		
Water	Shared well		

Total Acreage:	0.21
Total Sq. Ft:	9,148
Actual Frontage:	
Effective Frontage:	0
Effective Depth:	0
Water Influence:	None
Water Desirability:	None

*Legal Description		
PIGEON RIVER HEIGHTS LOT 10 BLK 2.		
*This legal description may be abbreviated and is for assessment purposes only.		
Section:	10	Township: 15
Subdivision:		Range: 23E
	Block:	Lot / Unit:

Inspection Data		
Date	User	Type

Property Sales / Ownership History						
Sale Date	Sale Price	Sale Typ	Validity	Document #	Deed Type	Grantor
3/11/2022	\$218,000	IMPROVED	2 - Valid improved sale	2133169	1 - Warranty	Wyckoff Keith J
8/15/1998	\$73,900		5 - Not a market sale		1 - Warranty	Wyckoff Keith J

Summary of 2025 Assessment Year Values					
Tax Classification	Code	Acres	Land	Improvement	Total
Residential	1	0.210	\$22,900	\$208,600	\$231,500
Total Real Estate - All Columns:		0.210	\$22,900	\$208,600	\$231,500

Assessment Value History					
Year	Code	Acres	Land	Improvement	Total
2025	1	0.210	\$22,900	\$208,600	\$231,500
	Totals	0.210	\$22,900	\$208,600	\$231,500
2024	1	0.210	\$22,900	\$208,600	\$231,500
	Totals	0.210	\$22,900	\$208,600	\$231,500
2023	1	0.210	\$21,000	\$132,200	\$153,200
	Totals	0.210	\$21,000	\$132,200	\$153,200

Special Tax Programs (MFL/PFC) and Exempt					
Tax Classification	Code	Acres	Land	Improvement	Total

Permit Information				
Issued Date	Number	Amount	Status	Purpose/Description
2019-04-29	30875	\$ 0	Completed	Fence on side of house
2007-07-24	19514	\$ 1050	Completed	Addition to garage
2007-04-05	19043	\$ 1500	Completed	Windows

2025 Assessment Year

Town of Sheboygan, Sheboygan County (2025 Assessment Year)

Property Records

Land Information										
Land Line	Tax Classification	MAR Subclass	Acres	Sq. Ft.	Width	Depth	Unit of Measure	Units	Unit Rate	Land Value
1	Residential		0.210	9,148	0	0	Square Feet	9,148.000	2.50	\$22,900
Total All Columns:			0.210	9,148						\$22,900

Other Building Improvements (OBI)											
Bldg #	Tax Class	Style	Class/Const	Year Built	Grade	Condition	Width	Length	Height	Units	OBI Value
2	Residential	Utility shed	Frame	2000	D	Fair	8	11	0	88	300
Total Columns:											300

Extra Features (XF)												
XF #	Tax Class	Code	Alt. Description	Assoc. Bldg	Year Built	Grade	Condition	Width	Length	Height	Units	XF Value
1	Residential	Well, shared drilled			0	C	Average	0	0	0	1	\$1,500
Total Columns:												\$1,500

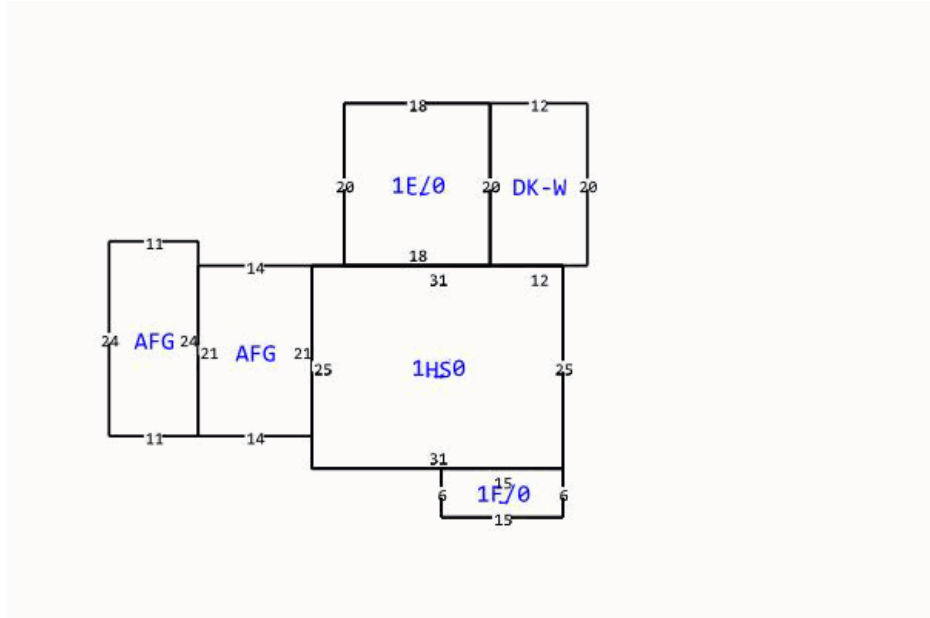

Building Data			
Tax Classification	Residential	Additional Fixtures	NO
Building Number/Section	1 - 1	Hot Tub	NO
Building Style	Cape Cod	Plumbing Rough In	NO
Quality/Grade	C	Family Rooms	NO
Year Built	1947	Other Rooms	NO
Effective Year Built	1947	Masonry Fireplace Stacks	NO
Class/Const	Brick / Stone	Masonry Fireplace Openings	NO
Overall Condition (CDU)	Average	Masonry Additional Stories	NO
Occupancy (Use)	Single Family	Metal Fireplace Stacks	YES
Living/Apartment Units	1	Metal Fireplace Openings	YES
Stories	1.5 story	Metal Additional Stories	NO
Roof Type	Asphalt shingles	Gas Fireplace Openings	NO
Basement Type	Not Specified	Equipment Rating	Average
Exterior Wall	Brick	Kitchen Rating	Average
Masonry Adjustment SF	-400	Bath Rating	Average
Shed Dormer LF	0	Interior Rating	Good
Gable Dormer LF	0	Exterior Rating	Average
Heating	Gas, forced air	Rec Room Rating	No Code
Air Conditioning	A/C (same ducts)		
Bedrooms	3		
Bath-Full	2		
Bath-Half	0		
Whirlpool	0		

Building Area					
Living Area	Sq. Ft.	Other Area	Sq. Ft.	Attachment Area	Sq. Ft.
First Floor Area	1,225	Unfinished Attic Area	0	Attached garage, frame	558
Second Floor Area	0	Unfinished Area	0	Deck, wood	240
Third Floor Area	0	Basement Area	865		
Half Floor Area	581	Crawlspace Area	360		
Finished Attic Area	0	Finished Basement Area (FBLA)	0		
		Rec Room Area	0		
Total Above Grade Living Area	1,806	Total Sq. Ft. Living Area (SFLA)	1,806		